



SERIES 20L FLOWGRID™ PILOTS INSTALLATION / OPERATION / MAINTENANCE MANUAL

This manual provides installation, operation and maintenance instructions for the Series 20L FLOWGRID™ PILOTS. Instructions for the FLOWGRID™ VALVE will be found in a separate manual. The manual is divided into the following sections:

Product Description	1-2
Materials Of Construction	2
Specifications	2-3
Pilot Markings	3
Nameplate Information	3
Principle of Operation	4
Installation	4-6
Piping Schematics	7-11
Start-up and Operation	12-14
Maintenance	14-19
Galvanic Corrosion	20
Sectional View	20
Warranty	20



The **SERIES 20L FLOWGRID™ PILOT** with Body Insert (Cartridge) removed.

PRODUCT DESCRIPTION

The SERIES 20L FLOWGRID™ PILOT is a low pressure control pilot designed primarily for use with unloading type pilot systems for pressure reducing (PRV) and differential pressure reducing applications. The Series 20L Pilot is designed for Gas and Liquid applications.

Series 20L-B Bronze construction with 5" W.C. to 8 PSI control pressure range.

Series 20L-A Aluminum construction with 5" W.C. to 8 PSI control pressure range.

The Series 20L Pilots utilize the same interchangeable cartridge used in the Series 20/20S/20H/20HS pilots. To avoid the possibility of corrosion between dissimilar metals refer to the alloys compatibility chart on page 20 before installing cartridges of dissimilar metals.

General Description (Refer to Figure 1)

Body Insert Assembly: A removable Body Insert Assembly (Cartridge), at the bottom of the Pilot Body, contains the inner valve mechanism. The inner valve is reversible so that the Main Spring will either open the valve (Pressure Reducing mode) or close the valve (Back Pressure or Relief mode). The cartridge may be replaced with a spare unit for fast trouble shooting or repair. The Body Insert Assembly is also field repairable.

NOTE: The Series 20L Pilot **MAY NOT** be used in the Back Pressure (BPV/Relief) mode to control the FLOWGRID™ VALVE because the Series 20L Pilot set point range is below the minimum differential required to open the FLOWGRID™ VALVE. Please contact your representative or Mooney Controls, Inc. regarding Series 20L back pressure applications.

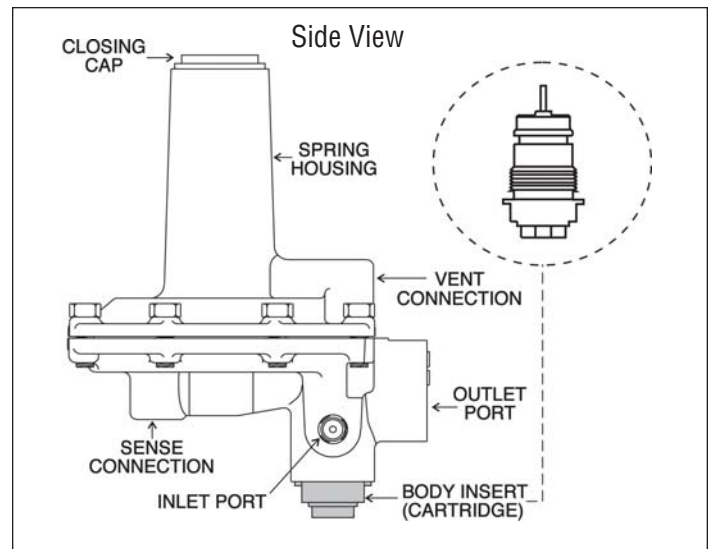

Figure 1 - The Series 20L Flowgrid™ Pilot.

PRODUCT DESCRIPTION (cont'd)

Spring Housing: The Pilot Spring Housing is provided with a 1/4 inch NPT vent connection which may be piped to a safe area or pressure loaded for remote control of the pressure setting. The Spring Housing may also be pressurized for use in differential pressure control or remote control applications. The Main Spring may be changed by simply removing the Closing Cap and Spring Adjuster.

Vent Orifice: A removable vent orifice is provided in the vent connection. This orifice provides dampening for additional stability but also reduces speed of response. Use or remove the vent orifice to optimize performance.

Inlet and Loading Ports: The inlet port is common with the loading port through an internal passage in the pilot. A Restrictor is normally connected directly to the inlet port. The loading port may be used to connect and mount the pilot to the loading chamber of the valve to be operated.

Sensing Port: The Series 20L pilot has separate sensing and outlet (discharge) connections. The sensing connection is “static” which means that there is no flow in the sensing line and the true pipeline pressure is measured at the diaphragm.

Outlet Port: The Outlet (discharge) port must be connected to the valve outlet or outlet pressure system. Separate Sensing and Outlet ports makes piping easier and facilitates the piping of working monitor and standby monitor systems.

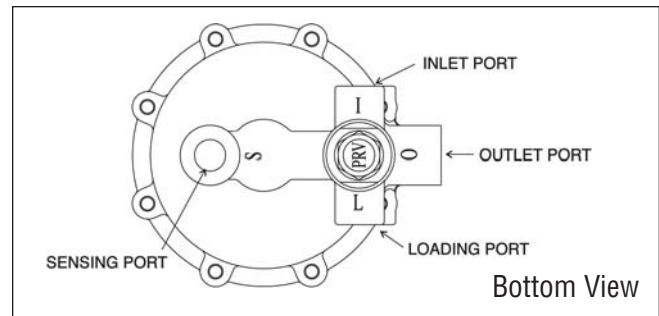

Figure 2 - The Series 20L Flowgrid™ Pilot.

MATERIALS OF CONSTRUCTION & SPECIFICATIONS

Materials of Construction

Series 20L - Aluminum & Bronze Construction *Table 1*

Body/Spring Housing	Cast Manganese Bronze	Case A356-T6 aluminum (anodized)
Body Insert/Closing Cap	Brass	6061 T-6 anodized aluminum
Bolting	304 stainless Steel	304 stainless steel
Cartridge Orifice	304 stainless Steel	304 stainless steel
Vent Orifice	304 stainless steel	304 stainless steel
Set Point Spring Adjuster	6061-T6 Aluminum	6061-T6 anodized
Plug & Stem	Nitrile/303 Stainless steel	Nitrile/303 stainless steel
Lever	Zinc plated carbon steel	Zinc plated carbon steel
Pivot	Brass	Aluminum (anodized)
Diaphragm Plate	6061-T6 anodzd. aluminum	6061-T6 anodized aluminum
Diaphragm Retainer	303 stainless Steel	303 stainless steel
Diaphragm	Nitrile/nylon	Nitrile/nylon
O-Rings	Nitrile	Nitrile

Specifications

Series 20L - Aluminum & Bronze Construction *Table 2*

	Series 20L (bronze)	Series 20L (alum.)
Body Style	Pressure reducing (PRV)	Same
Orifice Size	0.15 inches	Same
Connections	1/4" NPT inlet, outlet & loading, 1/2" NPT sense	Same
Temp.-Nitrile Diaphragm &	Working -20°F - 150°F Emergency -40°F - 175°F	Same
Max. Static Inlet Pressure	1500 psig*	750 psig*
Max. Static Outlet Pressure	1500 psig*	750 psig*
Max. Static Load Pressure	1500 psig*	750 psig*
Max. Operating Inlet Pressure	750 psig	750 psig
Max. Operating Load Pressure	750 psig	750 psig
Max. Operating Outlet Pressure	750 psig	750 psig
Max. Sensing Pressure	300 psig	150 psig
Max. Spring House Pressure	300 psig	150 psig
Set Pressure Spring Ranges	5 inches W.C. - 8 psig**	

* Static non-operating rating

**Refer to Table 3 (page 3) for specific spring ranges.

SPECIFICATIONS (cont'd)

Series	Spring Range	Color	Part Number
20L Aluminum & Bronze Constructions	5 inches W.C. - 15 inches W.C.	White	040-015-01
	5 inches W.C. - 40 inches W.C.	Brown	040-016-01
	1 - 3 psig	Yellow	040-017-01
	2 - 5 psig	Orange	040-018-01
	4 - 8 psig	Gray	040-019-01

PILOT MARKINGS

(Refer to Figure 3)

1. Location of the Pilot Nameplate. The Nameplate can be located on any two bolts for ease of identification.
2. Location of Spring Range Nameplate. The factory marks the nameplate to indicate which spring is installed at manufacture date. If the spring is changed, make sure to note it on the nameplate.
3. The month and year the pilot is manufactured is noted on the Spring Case, Body, and Body Insert of the pilot.

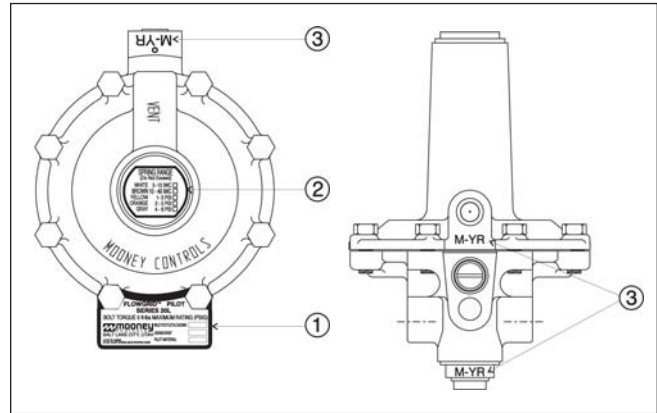

Figure 3

NAMEPLATE INFORMATION

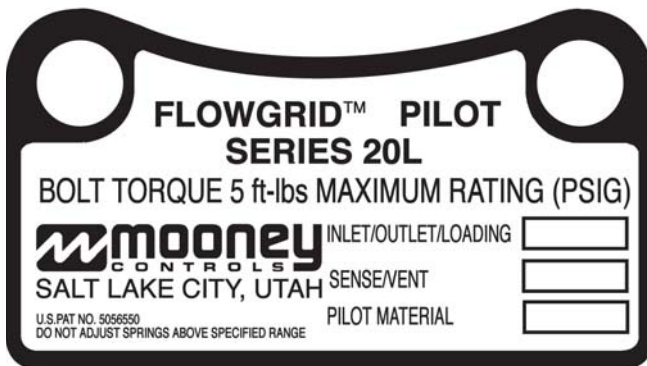

Figure 4 - Nameplate for Series 20L FLOWGRID™ PILOTS.

Item	Definition
FLOWGRID™ PILOT	Trade Marked name of pilot.
Series...	Model number of pilot.
Bolt Torque 5 ft-lbs.	The maximum dry bolt torque for the spring case bolts in foot pounds.
Inlet/Outlet/Loading	Max. allowable pressure (psig) to the Inlet, Outlet, and Loading ports.
Sense/Vent	Max. allowable pressure (psig) in the sense or vent ports.
Pilot Material	The material of construction for the pilot body and spring housing.



Figure 5 - Spring Range Nameplate for Series 20L FLOWGRID™ PILOTS.

Item	Definition
White, Brown, Yellow, Orange	Each spring is color coded to indicate the control pressure range.
Gray	

PRINCIPLE OF OPERATION

Pressure Reducing Application (PRV)

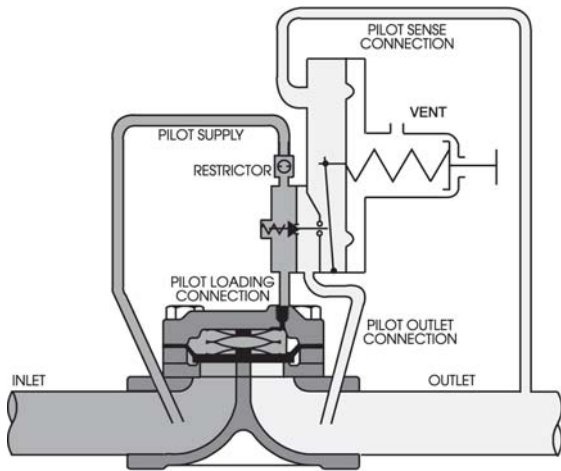

Figure 6 - Pressure Reducing Configuration Fully Closed.

At no flow, when the outlet pressure is greater than the set point of the pilot regulator, the pilot is closed and full inlet pressure loads the spring case through the pilot loading connection. In this condition the diaphragm is closed tightly against the throttle plate. The pressure differential across the outlet half of the diaphragm adds to the spring force in closing the FLOWGRID™ VALVE (refer to Figure 6).

As demand for flow occurs in the downstream system, the outlet pressure drops causing the pilot regulator to open and start bleeding fluid out of the spring case faster than it can enter through the restrictor, resulting in a reduction of pressure above the diaphragm. This allows the inlet pressure to progressively lift the diaphragm off the throttle plate, opening the valve and satisfying the demand for flow in the downstream system. (Refer to Figure 7).

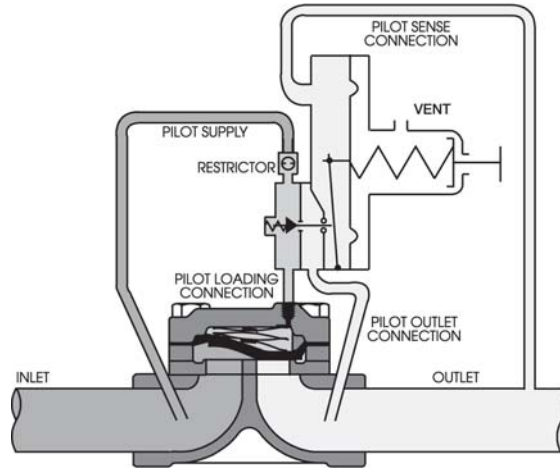

Figure 7 - Pressure Reducing Configuration Partially Open.

When demand for flow ceases or is reduced, the downstream pressure increases causing the pilot regulator to close. Inlet pressure continues to pass through the restrictor until the control pressure equals the inlet pressure. The spring force, plus the pressure differential across the outlet half of the diaphragm closes the diaphragm against the throttle plate, shutting off the flow (refer to Figure 6).

Adjustment of the restrictor affects the response rate, stability, and sensitivity of the regulator. Smaller restrictor openings result in higher gain (sensitivity) and slower closing speeds. Larger openings result in lower gain (greater proportional band), greater stability and faster closing speeds.

INSTALLATION

WARNING

Personal injury, equipment damage, or leakage due to explosion of accumulated gas or bursting of pressure containing parts may result if this valve/regulator is overpressured or is installed where service conditions could exceed the limits given in the specification of this manual or on the nameplate, or where conditions exceed any ratings of the adjacent piping or piping connections. Verify the limitations of both valve and pilot to ensure neither device is overpressured. To avoid such injury or damage,

provide pressure relieving or pressure limiting devices (as required by Title 49, Part 192, of the U.S. code of Federal Regulations, by the National Fire Codes of the National Fire Protection Association, or by other applicable codes) to prevent service conditions from exceeding those limits. Additionally, physical damage to the valve/regulator could break the pilot off the main valve, causing personal injury and/or property damage due to explosion of accumulated gas. Install the regulator in a safe location, to avoid such injury and damage.

INSTALLATION (cont'd)

1. **Personnel:** Installation of the FLOWGRID™ PILOT on the FLOWGRID™ VALVE or any other manufacturer's valve should be made by qualified personnel that are familiar with high pressure piping and pilot operated regulators.
2. **Prior Inspection:** Inspect the pilot for any damage that might have occurred in shipping.
3. **Control Action:** Inspect to make sure the Body Insert Assembly (Cartridge) is in pressure reducing mode. The Series 20L pilot utilizes the same reversible Body Insert Assembly as the Series 20 / 20S / 20H / 20 HS Pilots. The Series 20L Pilot MAY NOT be used in the Back Pressure (BPV/Relief) mode to control the FLOWGRID™ VALVE because the maximum Series 20L Pilot set point range is below the minimum differential required to open the FLOWGRID™ VALVE. Remove the Body Insert Assembly and measure the stem extension as shown below to confirm the pilot is in pressure reducing mode. If incorrect, follow the Body Insert Assembly disassembly and assembly instructions in the MAINTENANCE section of this manual (refer to Figure 8 and/or Page 17).
4. **Orientation:** The FLOWGRID™ PILOT may be installed in any position - the best position being one that provides easiest access for pilot adjustment and valve maintenance.
5. **Mounting Bracket:** A mounting bracket is recommended to firmly mount the Series 20L pilot to the FLOWGRID™ VALVE or any other regulator. The bracket may be connected to the spring case bolts on the Series 20L pilot but can not be thicker than 3/16" (refer to the PIPING SCHEMATICS section of this manual).
6. **Pilot Supply Lines:** Run a 3/8-inch tubing or 1/4-inch pipe supply line from the upstream piping or from the valve body connection on the inlet side of the valve to the pilot restrictor (or FILTER - refer to part 7). The pilot supply connection should have a full and clean opening.

NOTE: A shutoff valve is not required in the supply or discharge from the pilot, but if a valve is installed it should be a full opening type.

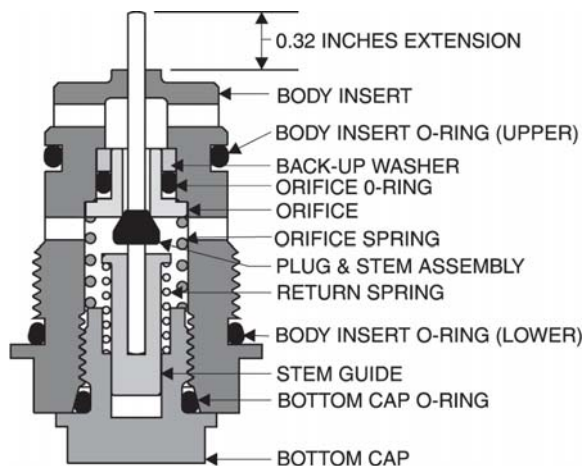

Figure 8 - The Body Insert assembly drawing, PRV mode.

WARNING

Gas Regulators installed in confined or enclosed spaces should be provided with adequate ventilation to prevent the possibility of gas buildup or accumulation from leaks and venting. Leaks or vented gas may accumulate causing personal injury, death, or property damage. Pilot spring cases and the regulator enclosure should be vented to a safe area away from air intakes, or any hazardous location. The vent lines and stacks must be protected against condensation and plugging.

7. **Pilot Supply Filter:** A filter such as the FLOWGRID™ Type 30 Filter is recommended in the pilot supply line to remove dirt and other particulates that could affect the restrictor or variable orifice in the pilot. Reference Type 30 Filter I/O/M manual for installation instructions.
8. **Pilot System Restrictor:** A rotary scratch type restricting valve (such as the TYPE 24 RESTRICTOR) must be mounted on the pilot supply line up stream of the INLET port of the Series 20L FLOWGRID™ PILOT. The restrictor may be mounted directly to the Inlet port of the Series 20L pilot (refer to PIPING SCHEMATICS section of this manual).
9. **Inlet & Loading Port:** The Series 20L Pilot has an INLET port which is common with the LOADING port through an internal passage in the pilot. The LOADING port can be directly connected to the loading connection on the FLOWGRID™ Valve or may be plugged and not used if other piping options are utilized. The Inlet port can also be plugged if the Loading connection is utilized for various piping configurations (refer to PIPING SCHEMATICS section of this manual).
10. **Pilot Discharge:** Run 3/8 inch tubing or 1/4 inch pipe from the pilot outlet port to the downstream piping or to the connection provided on the outlet of the Flowgrid™ valve as shown in the piping schematics (refer to page(s) 7 through 11).

INSTALLATION (cont'd)

STANDBY MONITOR NOTE: To ensure full capacity of a Standby Monitor regulator station, it is important that the pilot discharge of the upstream regulator be connected downstream of the station if the minimum pressure drop (across the entire station) is below 60 psig (refer to page10).

11. Control Lines: A Control line should be run from the SENSE Port of the FLOWGRID™ pilot mounted on the valve to a point 8 to 10 pipe diameters away from the valve (refer to Piping Schematics). Use Table 5 as a guide for the ideal tubing to use. Reduce as necessary to connect to the pilot. The FLOWGRID™ Series 20L Pilot sense connection is 1/2" NPT.

Table 4

Pilot Regulator with:	Outlet Pressure		
	Inches W.C. to 2 psi	2 psi to 5 psi	5 psi & above
Static Sense Line (no flow)	1/2" pipe minimum	1/2" tubing	3/8" tubing
Sense Line with flow	3/4"- 1" pipe	1/2" pipe	1/2" tubing

**All FLOWGRID™ Series 20 & 20L Pilots have a static sense line.*

NOTE: The control line connection should be away from areas of turbulence (such as valves, reducers, and elbows) and should have a full opening into the pipe, free from burrs, drill peels, and weld slag. Shut-off valves are not required in the control line(s), but if installed, they should be of the full opening type.

12. Interstage Piping (Working Monitor): On Working Monitor regulator stations the recommended length of the interstage piping is 6 pipe diameters or 36-inches, whichever is greater. It is also recommended that the interstage piping be swaged up 1 pipe diameter over the nominal port size of the valve (refer to page 11).

Examples:

- (1) If a station has two 3" Single Port FLOWGRID™ VALVES, the interstage piping should be at least 36-inches in length and swaged up to a 4" pipe.
- (2) If the station has 2 2"x1" FLOWGRID™ VALVES, (this valve has two inch flanges with a one inch port) the interstage piping should be at least 36-inches in length and a 2 inch pipe diameter.

13. **Token Relief:** On dead end systems, a token relief is recommended to compensate for slight leaks due to wear or debris in the monitor regulator and/or operating regulator.
14. **Spring Case Vent Connection:** a removable vent orifice is provided in the 1/4" NPT vent connection. This orifice provides dampening for additional stability but also reduces the speed of response. The orifice may be removed with a 3/16 allen wrench. Use or remove the vent orifice to optimize performance.

NOTES:

PIPING SCHEMATICS

The following piping schematics are provided:

1. Single Port Regulator (PRV). (Fig. 9)
2. Dual Port Regulator / Single Pilot (PRV). (Fig. 10)
3. Dual Port Regulator / Dual Pilot (PRV). (Fig. 11)
4. Standby Monitor with differential greater than 60 psig. (Fig. 12)
5. Standby Monitor with differential less than 60 psig. (Fig. 13)
6. Working Monitor. (Fig. 14)

NOTE: All drawings show installations with the Series 20L FLOWGRID™ PILOT equipped with Type 24 Restricting valve and Type 30 Filter. Consult factory for installation schematics of other manufacturers' pilots on the FLOWGRID™ VALVE.

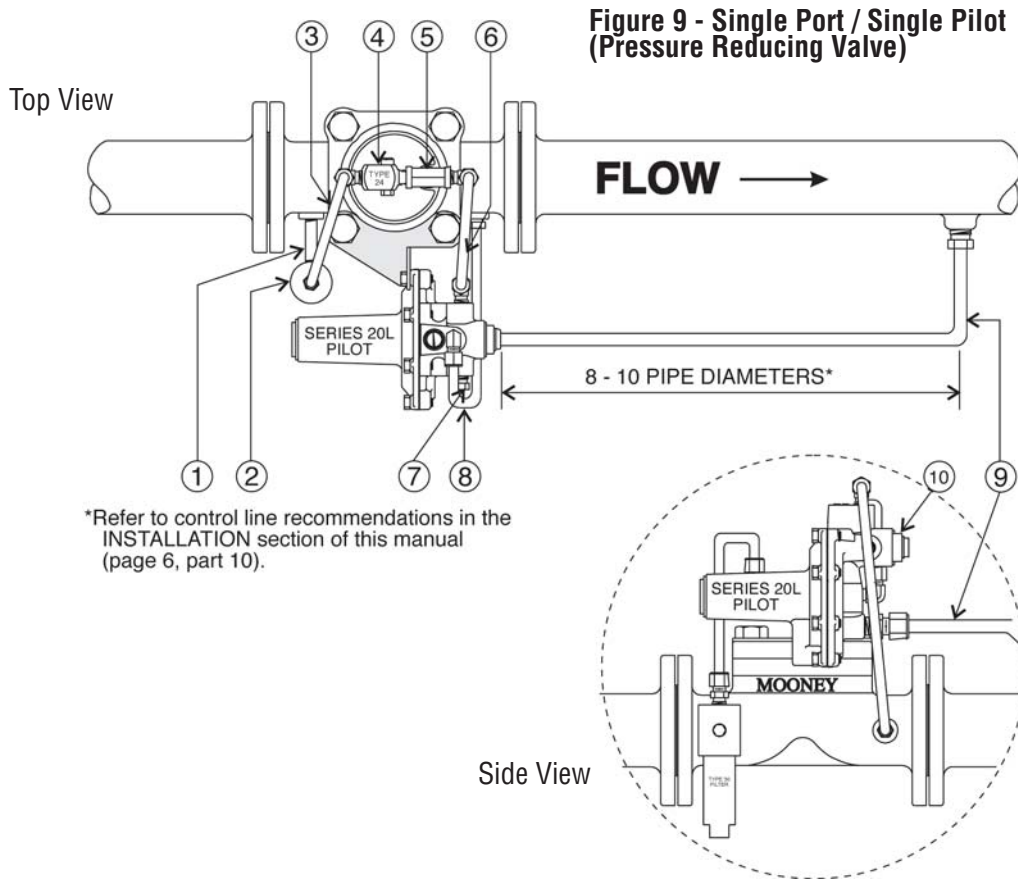

1. 1/4" NPT Schedule 80 nipple from inlet connection on valve body to Type 30 Filter inlet.
2. Type 30 Pilot supply filter (optional).
3. Outlet port of Type 30 Filter connected to Type 24 Restrictor inlet.
4. Type 24 Restrictor connected to Tee.
5. Schedule 80 Tee mounted to Loading connection on Spring Case of the FLOWGRID™ VALVE.
6. Outlet side of Tee connected to Loading port of the Series 20L FLOWGRID™ PILOT.
7. Inlet port[Ⓢ] of Series 20L pilot is plugged and not utilized in this piping configuration.
8. Outlet port of Series 20L Pilot connected to Outlet connection of FLOWGRID™ VALVE.
9. Sense line connecting Sense port on Series 20L Pilot to downstream piping.
10. Pilot cartridge in PRV mode.

Ⓢ **NOTE: The INLET port is common with the LOADING port through an internal passage in the pilot.**

PIPING SCHEMATICS (cont'd)

Figure 10 - Dual Port / Single Pilot (Pressure Reducing Valve)

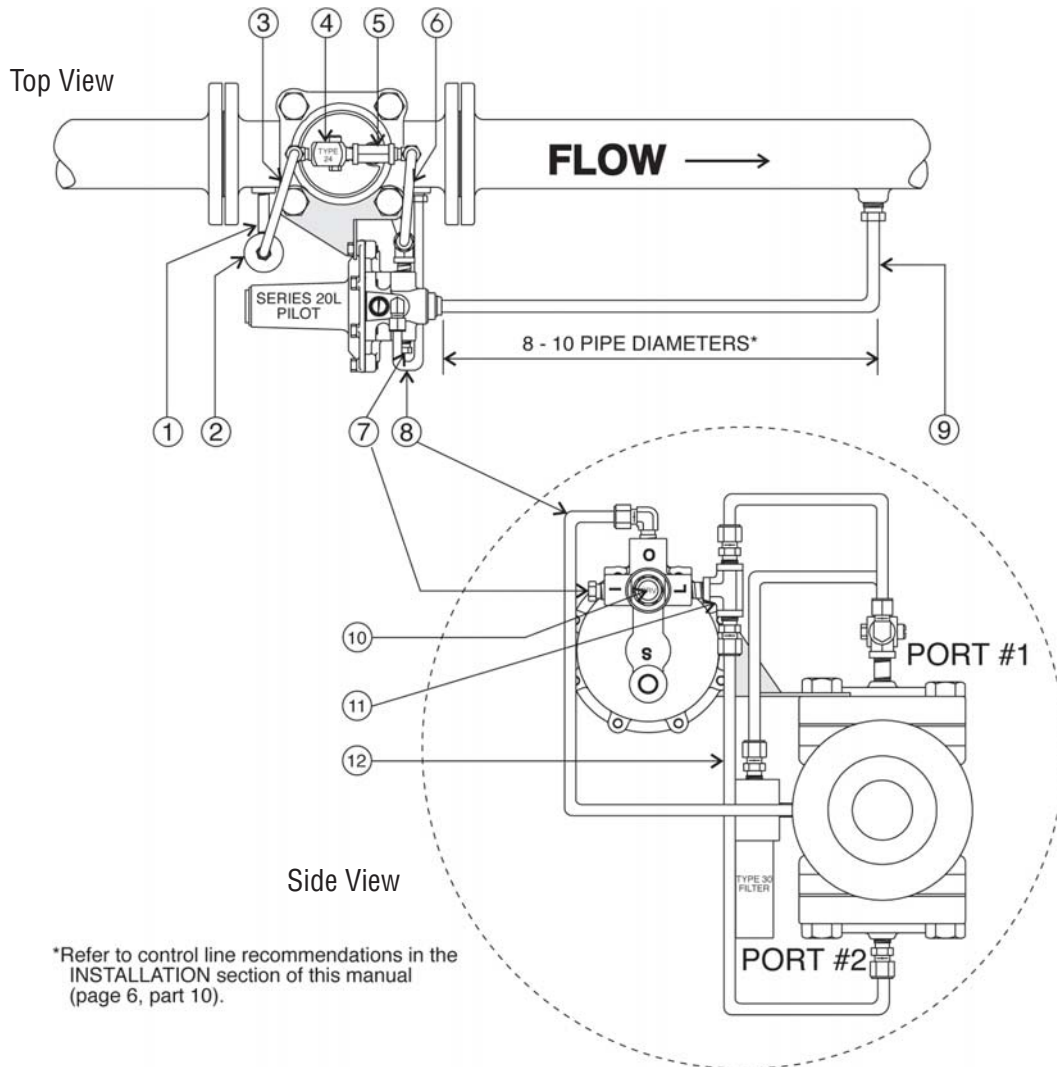

1. 1/4" NPT Schedule 80 nipple from inlet connection on valve body to Type 30 Filter inlet.
2. Type 30 Pilot supply filter (optional).
3. Outlet port of Type 30 Filter connected to Type 24 Restrictor inlet on Port #1 of the FLOWGRID™ Valve.
4. Type 24 Restrictor connected to Tee.
5. 1/4" NPT Schedule 80 Tee mounted to Loading connection on the Spring Case of the FLOWGRID™ Valve.
6. Outlet side of Tee connected to Inlet side of Tee which is mounted on the Loading port of the Series 20L FLOWGRID™ Pilot.
7. Inlet port[Ⓢ] of Series 20L pilot is plugged and not utilized in this piping configuration.
8. Outlet port of Series 20L Pilot connected to Outlet connection of FLOWGRID™ VALVE.
9. Sense line connecting Sense port on Series 20L Pilot to downstream piping.
10. Pilot cartridge in PRV mode.
11. 1/4" NPT Schedule 80 Tee mounted to Loading connection of Series 20L Pilot.
12. Outlet of Tee connected to Loading connection of Port #2 of the FLOWGRID™ Valve.

Ⓢ NOTE: The INLET port is common with the LOADING port through an internal passage in the pilot.

PIPING SCHEMATICS (cont'd)

Figure 11 - Dual Port / Single Pilot (Pressure Reducing Valve)

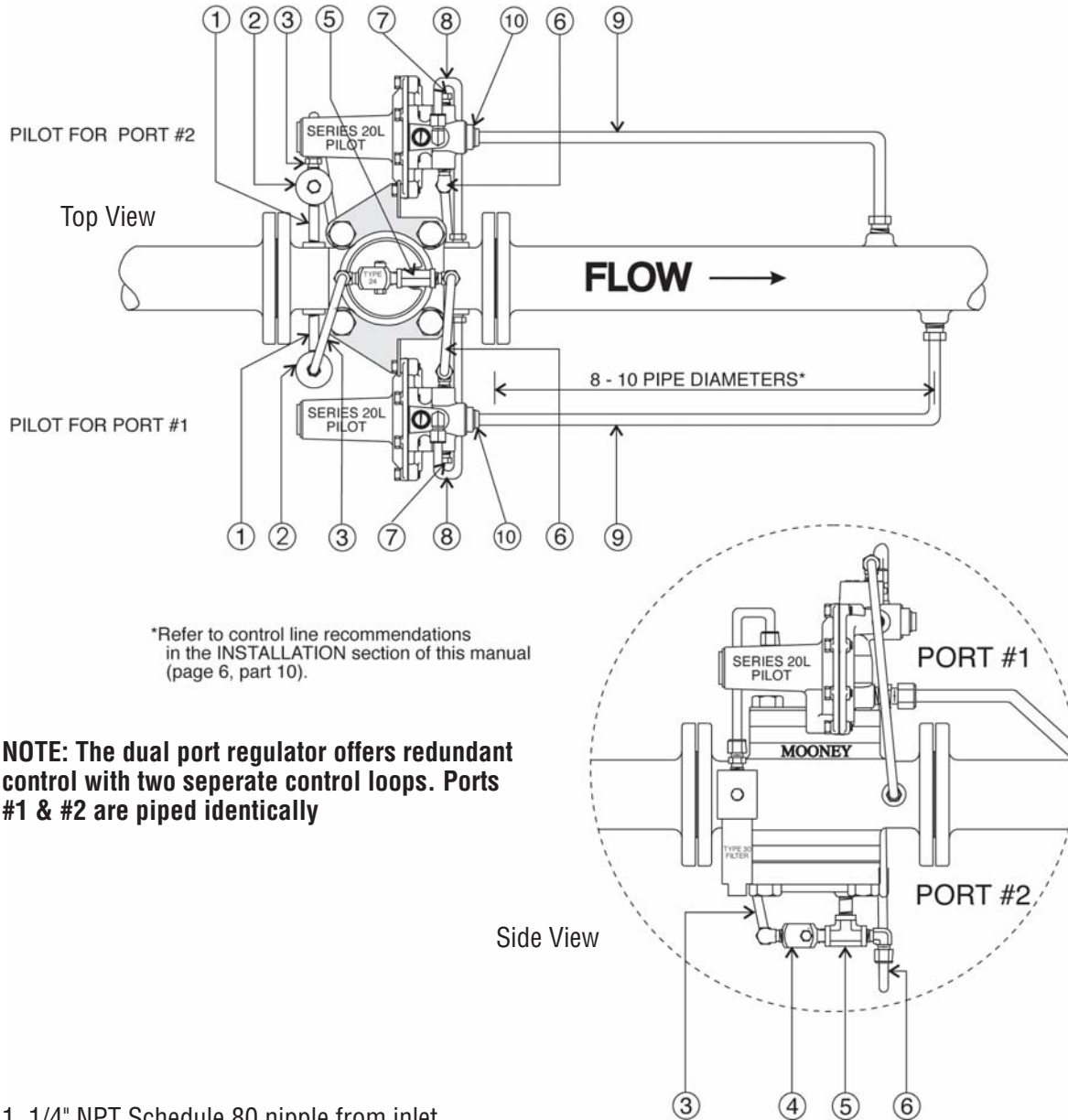

*Refer to control line recommendations in the INSTALLATION section of this manual (page 6, part 10).

NOTE: The dual port regulator offers redundant control with two separate control loops. Ports #1 & #2 are piped identically

1. 1/4" NPT Schedule 80 nipple from inlet connection on valve body to Type 30 Filter inlet.
2. Type 30 Pilot supply filter (optional).
3. Outlet port of Type 30 Filter connected to Type 24 Restrictor inlet on Port #1 & Port #2.
4. Type 24 Restrictor connected to Tee.
5. 1/4" NPT Schedule 80 Tee mounted to Loading connection on the Spring Case of the FLOWGRID™ VALVE.
6. Outlet side of Tee connected to Loading port of the Series 20L FLOWGRID™ PILOT.
7. Inlet port[Ⓞ] of Series 20L pilot is plugged and not utilized in this piping configuration.
8. Outlet port of Series 20L Pilot connected to Outlet connection of FLOWGRID™ VALVE.
9. Sense line connecting Sense port on Series 20L Pilot to downstream piping.
10. Pilot cartridge in PRV mode.

Ⓞ NOTE: The INLET port is common with the LOADING port through an internal passage in the pilot.

PIPING SCHEMATICS (cont'd)

Figure 12 - Standby Monitor with Differential Pressure Greater than 60 psig

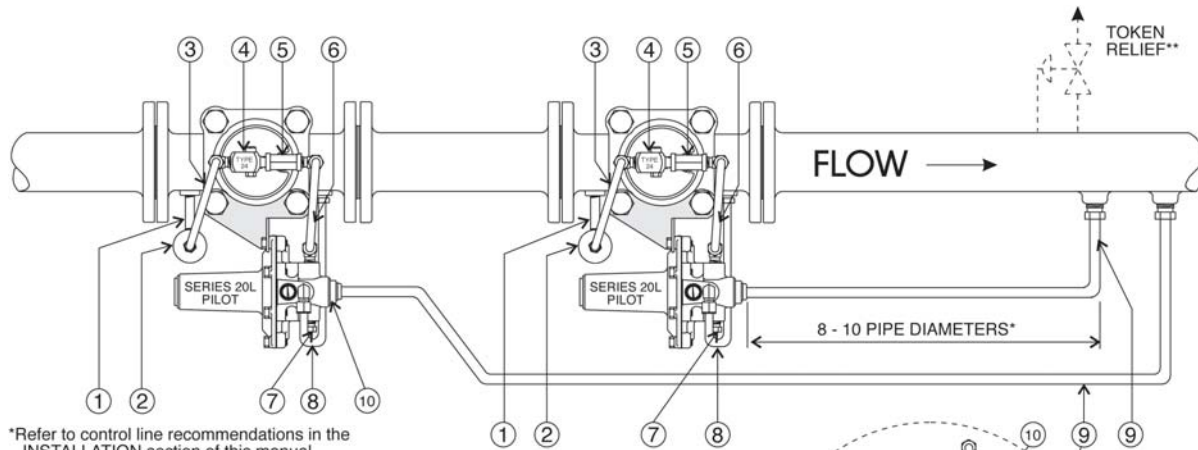

*Refer to control line recommendations in the INSTALLATION section of this manual (page 6, part 10).

**Refer to token relief recommendations in the INSTALLATION section of this manual (page 6, part 12).

1. 1/4" NPT Schedule 80 nipple from inlet connection on valve body to Type 30 Filter inlet.
2. Type 30 Pilot supply filter (optional).
3. Outlet port of Type 30 Filter connected to Type 24 Restrictor inlet.
4. Type 24 Restrictor connected to Tee.
5. 1/4" NPT Schedule 80 Tee mounted to Loading connection on Spring Case of the FLOWGRID™ VALVE.
6. Outlet side of Tee connected to Loading port of the Series 20L FLOWGRID™ PILOT.
7. Inlet port[Ⓢ] of Series 20L pilot is plugged and not utilized in this piping configuration.
8. Outlet port of Series 20L Pilot connected to Outlet connection of FLOWGRID™ VALVE.
- 8A. Alternate Outlet: Outlet port of Series 20L Pilot connected to downstream piping. Outlet connection of the FLOWGRID™ VALVE is plugged and not utilized in this piping configuration (refer to Figure 13).
9. Sense line connecting Sense port on Series 20L Pilot to downstream piping.
10. Pilot cartridge in PRV mode.

Ⓢ NOTE: The INLET port is common with the LOADING port through an internal passage in the pilot.

Figure 13 - Standby Monitor with Differential Pressure Less than 60 psig

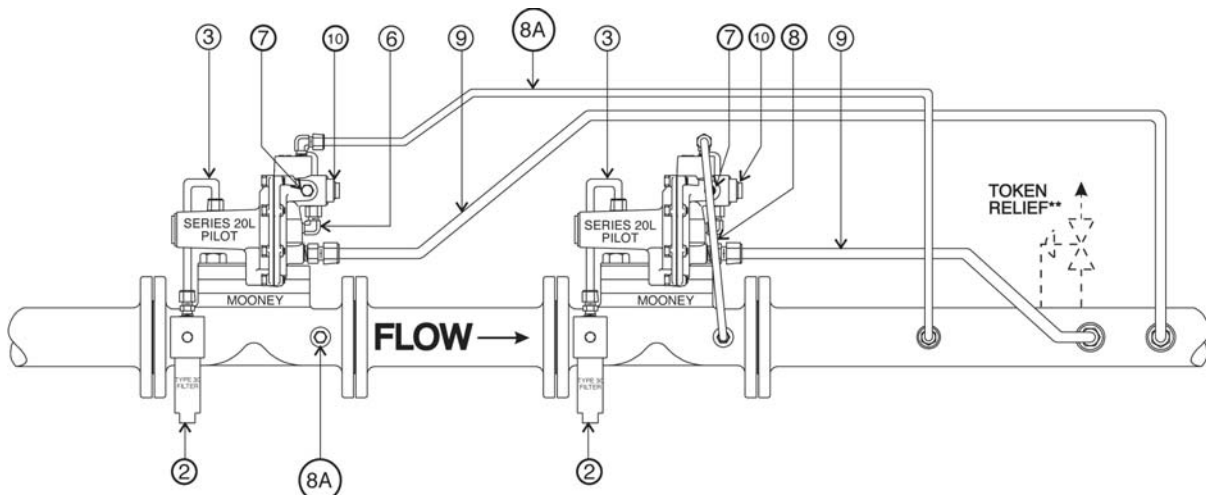

PIPING SCHEMATICS (cont'd)

Figure 14 - Working Monitor (Also Refer to Schematic on Page 14)

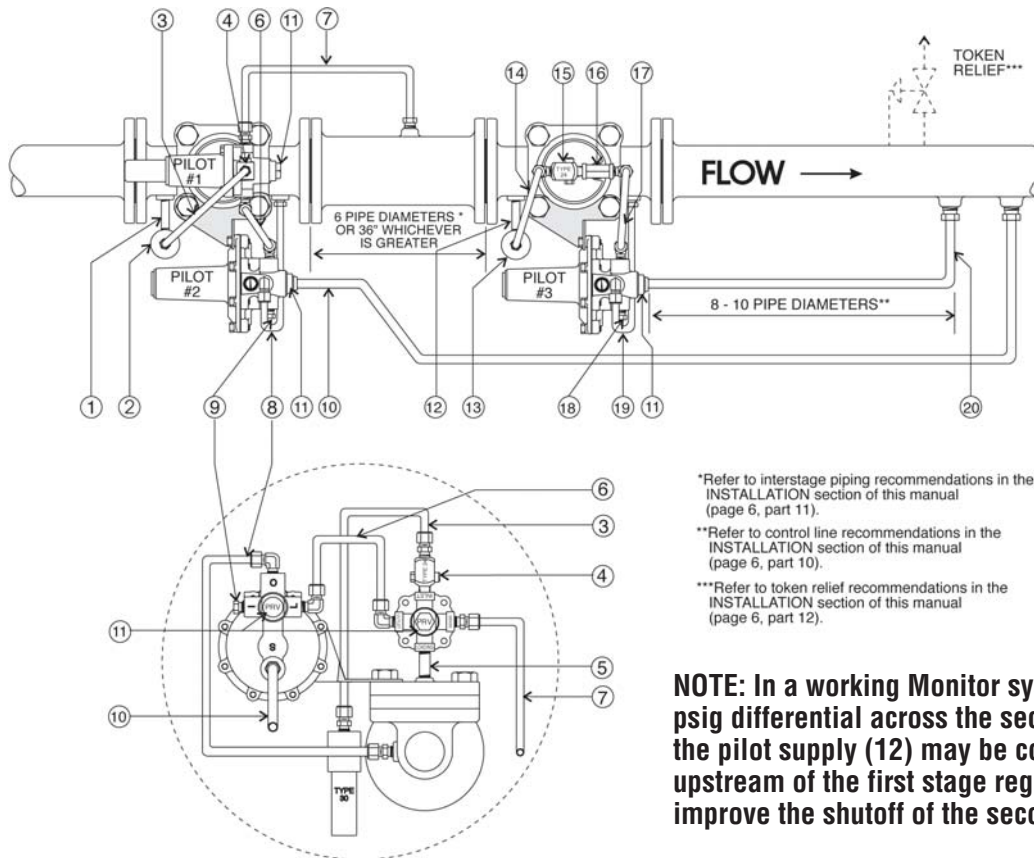

1. 1/4" NPT Schedule 80 nipple from inlet connection on valve body to Type 30 Filter inlet.
2. Type 30 Pilot supply filter (optional).
3. Outlet port of Type 30 Filter connected to Type 24 Restrictor inlet.
4. Type 24 Restrictor mounted to Inlet port of Series 20 Pilot (#1).
5. Loading Port of Series 20 Pilot (#1) connected to Loading connection on Spring Case of the FLOWGRID™ VALVE (hidden by Pilot #1).
6. Outlet port of Series 20 Pilot (#1) connected to Loading port of the monitor Series 20L Pilot(#2).
7. Sense line connecting sense port on Series 20 Pilot (#1) to interstage piping.
8. Outlet port of Series 20L Pilot (#2) connected to Outlet connection of FLOWGRID™ VALVE.
9. Inlet port^① of Series 20L Pilot (#2) is plugged and not utilized in this piping configuration.
10. Sense line connecting sense port on the monitor Series 20L Pilot (#2) to downstream piping.
11. All pilot cartridges in PRV mode.
12. 1/4"NPT Schedule 80 nipple from inlet connection on valve body to Type 30 Filter inlet.
13. Type 30 Pilot supply filter (optional).
14. Outlet port of Type 30 Filter connected to Type 24 Restrictor inlet.
15. Type 24 Restrictor connected to Tee.
16. 1/4" NPT Schedule 80 Tee mounted to Loading connection on Spring Case of the FLOWGRID™ VALVE.
17. Outlet side of Tee connected to Loading port of the Series 20L FLOWGRID™ Pilot #3.
18. Inlet 1 port of Series 20L Pilot is plugged and not utilized in this piping configuration.
19. Outlet port of Series 20L Pilot connected to Outlet connection of FLOWGRID™ VALVE.
20. Sense line connecting Sense port on Series 20L Pilot #3 to downstream piping.

① NOTE: The INLET port is common with the LOADING port through an internal passage in the pilot.

START UP AND OPERATION

The following procedures are suggested for start up of the FLOWGRID™ VALVE with the FLOWGRID™ SERIES 20L PILOT. Start up of the FLOWGRID™ VALVE/ regulator should be made by qualified personnel familiar with high pressure systems and pilot operated regulators.

1. Adjust the pilot restrictor to an intermediate opening (a "4" setting on the Mooney Controls Type 24 Restrictor).
2. Back off on the pilot Spring Adjuster to fully relieve all the spring compression.
3. If installed, open hand valve(s) in the control line(s), and the pilot supply line.
4. Crack open downstream block valve or open vent in piping downstream of the FLOWGRID™ VALVE.
5. Slowly open the upstream block valve to pressurize the FLOWGRID™ VALVE and pilot system. The FLOWGRID™ VALVE should lock up (shut off) with zero pressure downstream.
6. Open the vent in the downstream piping or slowly open the outlet block valves.
7. Slowly increase the pilot spring setting until some flow is achieved through vent or into downstream system. Adjust the pilot restrictor for stability and performance as follows:
 - a. If the system is stable, adjust the pilot restrictor to a more closed position (towards MIN setting). Change the flow rate or increase the pilot setting to check the reaction of the system during an upset.
 - b. If the system is stable, repeat step (a) until the system is unstable (oscillating).
 - c. Now readjust the restriction to a more open position (towards MAX setting) where the system is stable.
 - d. Vary the flow rate over as wide a range as possible to make sure the system will be stable under all flow conditions.

NOTE: Adjustment of the restrictor affects the response rate, stability, and sensitivity of the regulator. CLOSING the pilot restrictor will result in higher gain (narrower proportional band), more sensitivity, and slower closing speeds. OPENING the pilot restrictor will result in less gain (increased proportional band), less sensitivity, and faster closing speeds.

8. Slowly increase the pilot spring setting until the desired downstream pressure is achieved.
9. Depending on the performance of the regulator you may remove or leave installed the orifice in the pilot vent connection. Leaving the orifice in will increase stability but reduce speed of response.
10. Slowly close the downstream block valve or vent to check the FLOWGRID™ VALVE for lockup (shut off).
11. Slowly open the downstream block valve.

Standby Monitor

Refer to figure 15

NOTE: This procedure is based on the 1st Regulator being the operating regulator and the 2nd regulator being the monitor regulator.

1. Set operating pilot (#1) spring at the maximum setting.
2. Set monitor pilot (#2) spring to the MINIMUM (zero) setting.
3. Slowly open inlet block valve. Purge, if necessary, any pressure in the station. Full inlet pressure should be present at the Monitor Regulator and the Monitor Regulator should be closed.
4. Open vent or downstream block valve.
5. Increase the pilot spring setting of the Monitor Regulator until the desired monitor override setting is reached.
6. With some flow going through the station, start to lower the operating pilot setting of the Operating Regulator until the desired outlet pressure is achieved.

NOTE: When the set point of the Operating Regulator becomes less than the set point of the Monitor regulator, the interstage pressure will drop from approximately full inlet pressure to 5-10 PSI above the outlet pressure at low flow rates.

START UP AND OPERATION (cont'd)
Standby Monitor (cont'd)

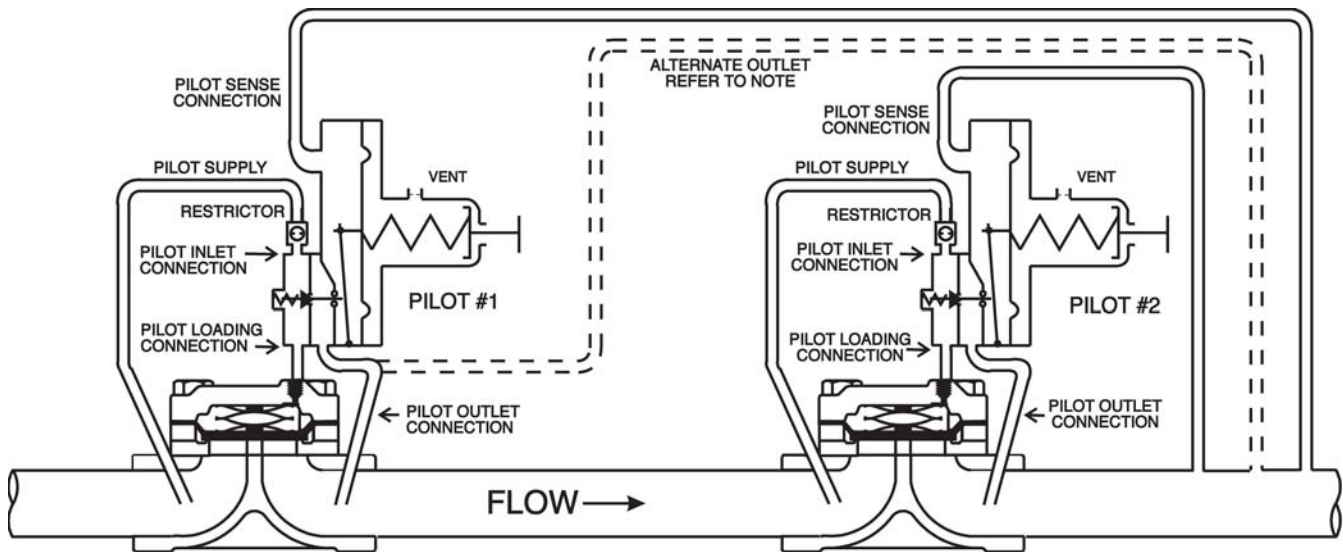

Figure 15 - Standby Monitor Schematic.

NOTE: When the pressure differential across the entire station (P1-P2) is less than 60 PSIG use the alternate Pilot Outlet as shown above to insure full station capacity.

1. With flow going through the station, slowly increase the setting of the Operating Regulator. When the outlet pressure reaches the setpoint of the Monitor Regulator, the monitor should take control and the interstage pressure should increase to almost full inlet pressure.
2. Reduce the setting of the Operating Regulator back to the required outlet pressure. The interstage pressure should drop to 5-10 PSI above the outlet pressure as the Operating Regulator takes control.

Standby Monitor

Refer to figure 15

1. Purge station and open outlet valve or vent to allow flow through the station.
2. Set 2nd Stage pilot (#3) to a high setting above desired setpoint.
3. Set 1st Stage pilot (#1) to a high setting above desired set point.
4. Set the Monitor pilot (#2) at a zero setting.
5. Set restrictor on Pilot (#1) at an intermediate opening (a "4" setting on the Mooney Controls Type 24 Restrictor).
6. Slowly open the inlet block valve to station. The 1st Stage Regulator should remain closed as a result of the Monitor Pilot (#2) being set to zero.
7. Increase the setting of the Monitor Pilot (#2) to the desired pressure setting. If the valve is unstable, increase the restrictor opening until it becomes stable.
8. Lower the setpoint of the 2nd stage regulator (Pilot #3) to the desired outlet pressure setting. Tune the restrictor on Pilot (#3) at this time. The 1st stage regulator should open or begin to control the interstage pressure at the setpoint of Pilot (#1).
9. Adjust the setpoint of Pilot (#1) to achieve the desired Interstage pressure. Tune the restrictor on Pilot (#1) at this time.
10. Raise the setpoint of Pilot (#3) to verify the setpoint of the Monitor Pilot (#2). Adjust if necessary. Check for system stability and adjust the restrictor on Pilot (#1) if required.
11. Return setpoint of Pilot (#3) to maintain the desired outlet pressure.

START UP AND OPERATION (cont'd)
Working Monitor (cont'd)

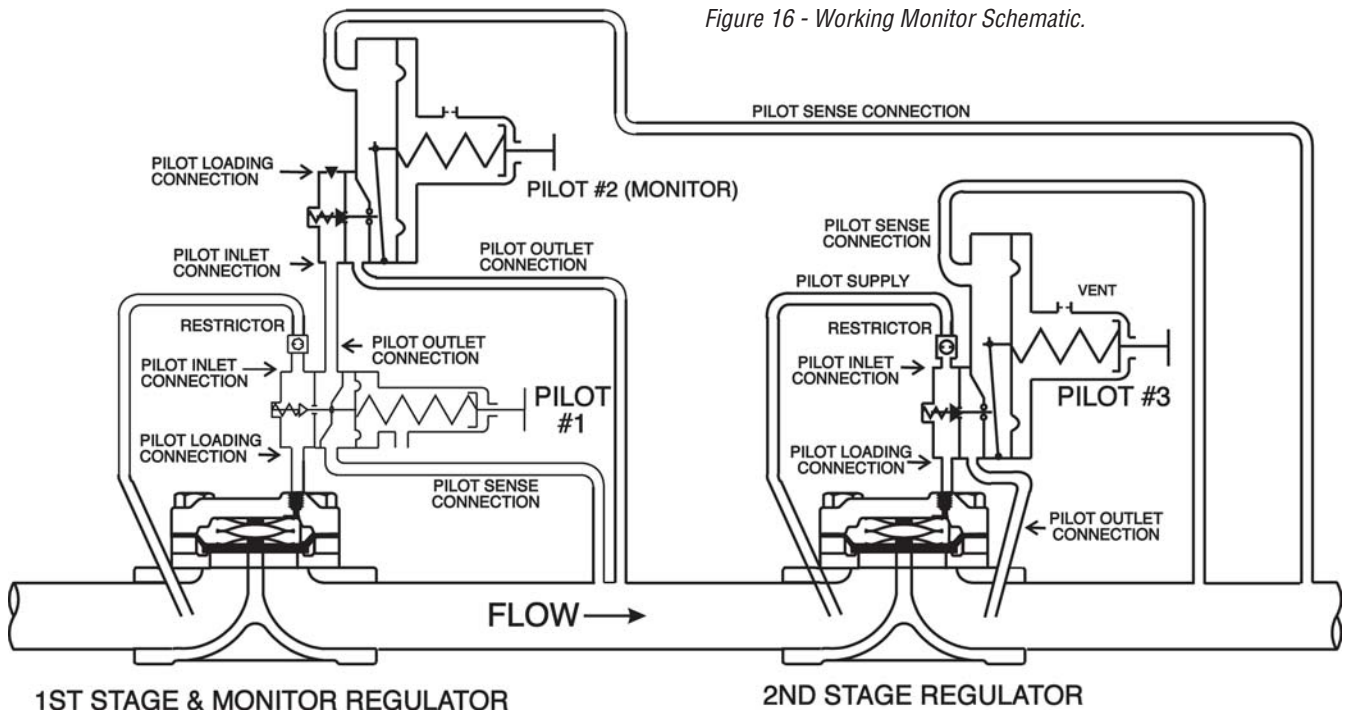

Figure 16 - Working Monitor Schematic.

MAINTENANCE

Pilot parts are subject to normal wear and must be inspected and replaced as necessary. The frequency of inspection and replacement of parts depends on severity of service conditions and/or the requirements of local, state, and federal regulations. Be certain that the name plates are updated to accurately indicate any field changes in equipment, materials, service conditions, or pressure settings.

Pilot Disassembly

Series 20L - Aluminum & Bronze Constructions

1. After depressurizing the pilot and main valve unscrew and remove the Body Insert Assembly.
2. Remove the Stem O-ring from the pilot body using a suitable tool. Be careful not to scratch the O-ring Groove (refer to Figure 17).

WARNING

Before disassembly make sure the regulator and pilot have been isolated from the process by closing block valves on the inlet and outlet sides of the regulator. Safely release pressure and process fluid from the regulator body and pilot system. Failure to properly complete these steps may result in personal injury and/or property damage.

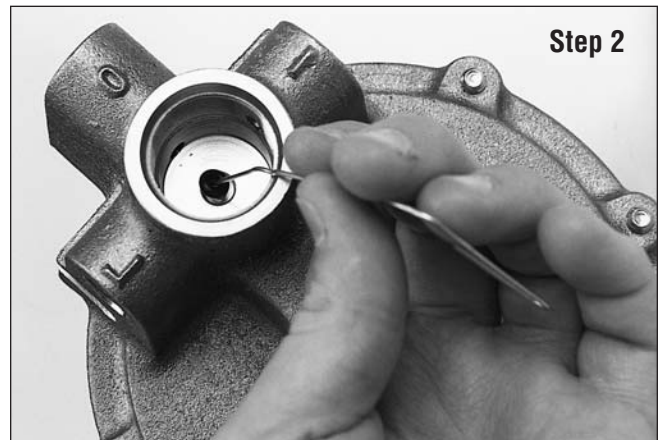

Figure 17 - A paper clip easily pops the O-Ring out of the pilot body.

MAINTENANCE (cont'd)

Pilot Disassembly (cont'd)

NOTE: A spare Body Insert Assembly may be installed and the regulator returned to service if time is a factor. Make sure the Stem O-Ring is still in place in the Pilot Body before installing the new Body Insert Assembly or, if removed, slip a new O-Ring over the Stem of the Body Insert Assembly prior to installing it in the Pilot Body.

3. Remove the Bottom Cap from the Body Insert and remove the internal parts. The Orifice Assembly can be easily pushed out of the Body Insert using a heavy paper clip or .045 diameter wire (refer to Figure 18).

NOTE: Do not damage the O-Ring sealing surface of the Body Insert.



Figure 18 - The orifice can be pushed out of the Body Insert (Cartridge) using a paper clip.

4. Remove top Cover from the spring barrel of the pilot and release spring tension by unscrewing the Spring Adjuster (refer to Figure 19).

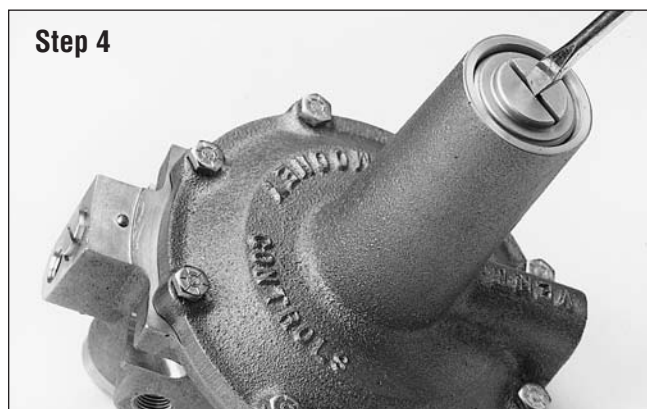

Figure 19 - The spring tension is released by unscrewing the Spring Adjuster.

5. Unscrew and remove the threaded Retainer Plug on the side of the Series 20L pilot just above the outlet port (refer to Figure 20).

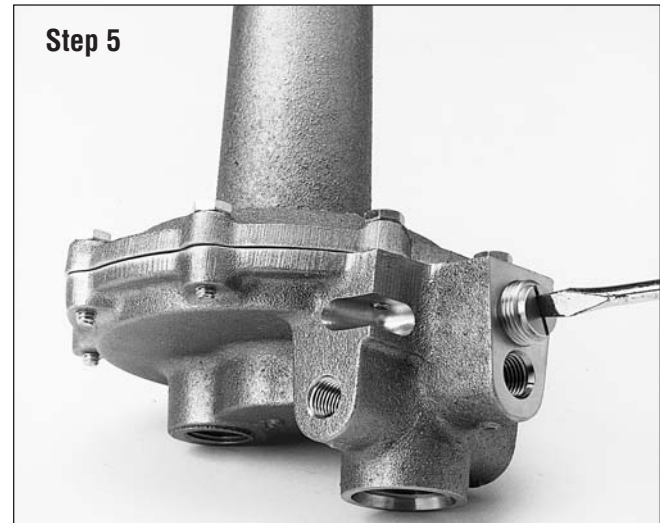

Figure 20. Remove the Threaded Retainer Plug.

6. Screw a 5/16-18 UNC bolt into the Pivot and pull the Pivot & Lever assembly out of the Pilot Body (refer to Figure 21).



Figure 21. Pull the Pivot & Lever Assembly out of the Pilot Body.

5. Remove the eight bolts joining the Spring Case to the Pilot Body. Separate the Spring Case from the Pilot Body, the Main Spring and Spring Washers.
6. Remove Diaphragm Assembly. Disassemble assembly simply by removing the retaining nut.
7. Inspect all parts for wear or damage. Replace as necessary.

MAINTENANCE (cont'd)

Pilot Assembly

Series 20L - Aluminum & Bronze Constructions

O-Ring Lubrication Note: Use Parker Super O-Lube™ or an equivalent silicone based lubricant on all O-Rings in the FLOWGRID™ Series 20L Pilot.

1. Place a lubricated O-Ring onto the Pivot & Lever Assembly as shown below. Also lubricate the area where the lever pivots on the roll pin with a petroleum grease such as Lubriplate No. 1051 (Refer to Figure 22).

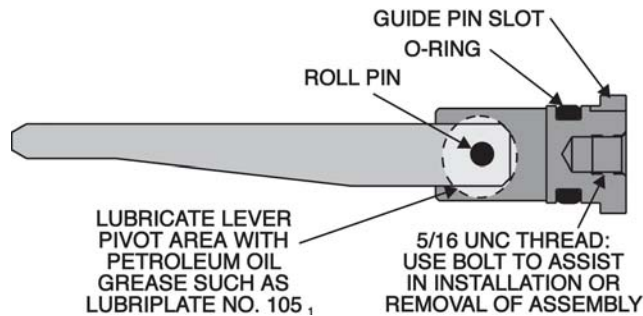

Figure 22 - The Pivot & Lever Assembly.

2. Loosely screw a 5/16"-18 UNC bolt into the threaded area on the Pivot & Lever assembly to help push it into the Pilot Body. A guide pin assures the Pivot & Lever assembly is correctly oriented in the Pilot Body. Unscrew and remove the bolt when complete (refer to Figure 22 & 23).

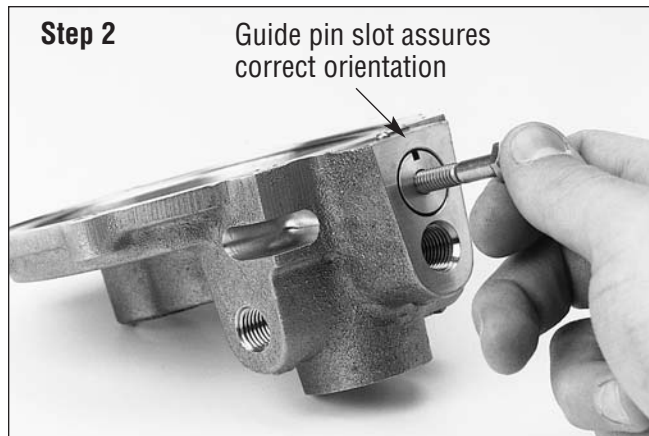

Figure 23 - Use a 5/16"-18 UNC bolt to push the Pivot plug / Lever assembly into place. Remove the bolt when complete.

3. Screw the threaded Pivot Retainer onto the Pilot Body to hold the Pivot & Lever Assembly in place. The Pivot Retainer should be flush with the Pilot Body when installed correctly (refer to Figure 24).

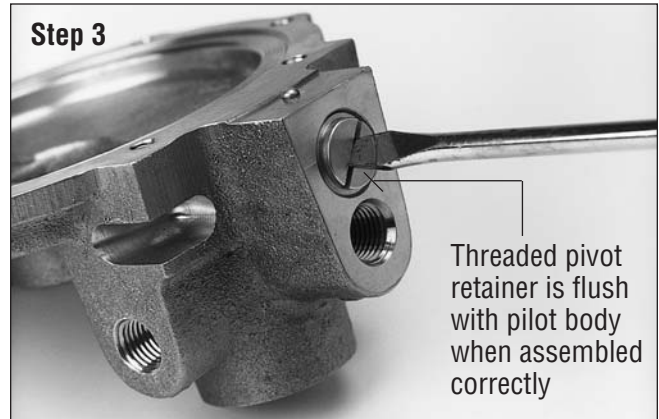

Figure 24 - Screw the Retainer Plug firmly into place.

4. **Diaphragm Assembly:** Assemble the Pilot Diaphragm with the convex side toward Diaphragm Plate and Main Spring (refer to Figure 25). Tighten nut on the Diaphragm Retainer to approximately 5 to 6 ft-lbs torque.

NOTE: Overtightening will distort the Pilot Diaphragm.

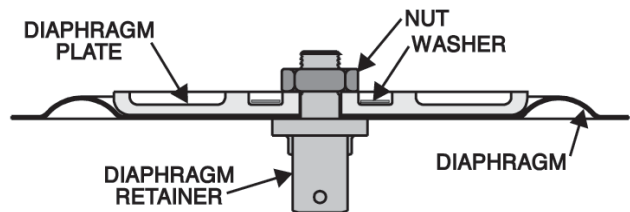

Figure 25 - The Series 20L Pilot Diaphragm Assembly.

5. Slide the diaphragm assembly onto the lever as shown below. The lever must rest on the pivot pin. Rotate the Diaphragm Assembly to locate the lever in the center of the Diaphragm Retainer. The lever must be centered to prevent binding. No lubrication on the pivot pin is necessary (refer to Figure 26).

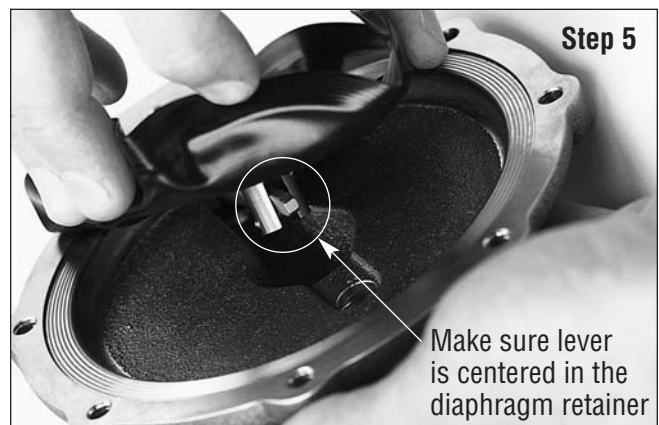

Figure 26 - Slide the Diaphragm Assembly onto the Lever .

MAINTENANCE (cont'd)

Pilot Assembly (cont'd)

Series 20L - Aluminum & Bronze Constructions

Body Insert (Cartridge) Assembly

Pressure Reducing (PRV) Mode

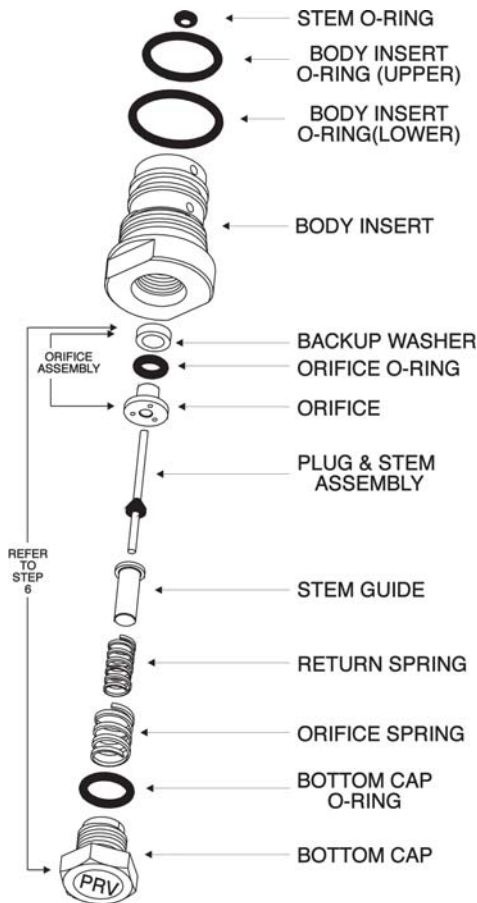

Figure 27 - Body Insert (Cartridge) Exploded view - Pressure Reducing Mode (PRV).

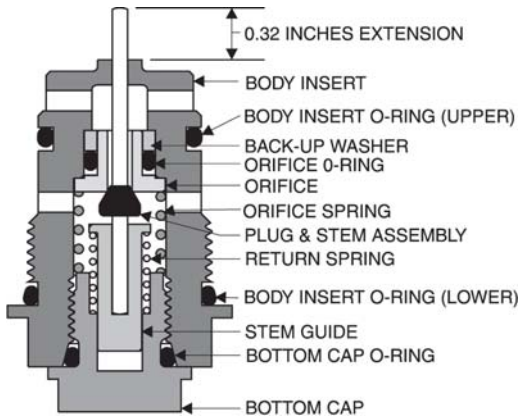

Figure 28 - Body Insert (Cartridge) Assembly drawing - Pressure Reducing mode (PRV).

- Place the O-Ring on the Bottom Cap and stack the following parts on the Bottom Cap in the order shown in the drawing: Return Spring, Stem Guide, Orifice Spring, Plug and Stem, Orifice, Orifice O-Ring and Back-up Washer (Refer to Figures 27, 28 & 29).



Figure 29 - Stack the Return Spring, Stem Guide, Orifice Spring, Plug and Stem, Orifice, Orifice O-Ring, and Back-up Washer on the Closing Cap.

- Body Insert Assembly:** Lift Bottom Cap complete with valve mechanism and insert into Body Insert. The Orifice Spring should snap the Orifice into place as the Bottom Cap is screwed into place. Check the assembly by pushing the Stem against a hard surface to make sure it moves freely and returns to the extended position. Measure the stem extension, it should extend 0.32 inches away from the Body Insert (refer to Figure 28 & 30).

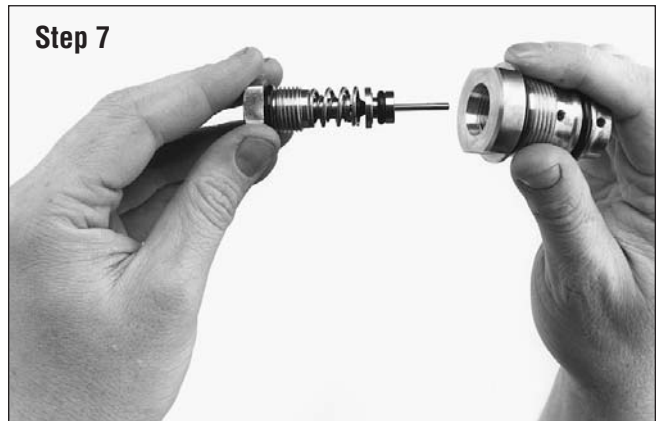

Figure 30 - Insert the assembly into the Body Insert- the orifice should "snap" into place.

MAINTENANCE (cont'd)

Pilot Assembly (cont'd)

Series 20L - Aluminum & Bronze Constructions

8. Lubricate Stem O-Ring with Parker Super-O-Lube1 (or equivalent Silicon Lubricant) and slip over Stem.
9. Insert the Body Insert (Cartridge) assembly into the Pilot body and screw into place snugly. Make sure the Stem O-Ring is lubricated and in place on the Stem of the Body Insert (refer to Figure 31.)



Figure 31 - Insert Body Insert (Cartridge) with lubricated Stem O-Ring into the Pilot Body.

NOTE: Overtightening an O-Ring Joint will not improve the seal. Tighten until metal parts make contact and snug slightly.

NOTE: The Series 20L Pilots utilize the same interchangeable cartridge used in the Series 20/20S/20H/20HS pilots. Due to the possibility of corrosion between dissimilar metals refer to the alloys compatability chart on page 20 before installing cartridges of dissimilar metals. The Series 20L Pilot MAY NOT be used in the Back Pressure (BPV/Relief) mode to control the FLOWGRID™ VALVE (or any other valve that utilizes the unloading type pilot systems) because the maximum Series 20L Pilot set point range is below the minimum differential required to open the FLOWGRID™ VALVE. Contact your representative or Mooney Controls, Inc. for Series 20L back pressure applications.

10. Place one Spring Washer onto the Diaphragm Plate. The washer prevents the Main Spring from "binding" on the Diaphragm Assembly when it is compressed (refer to Figure 32).

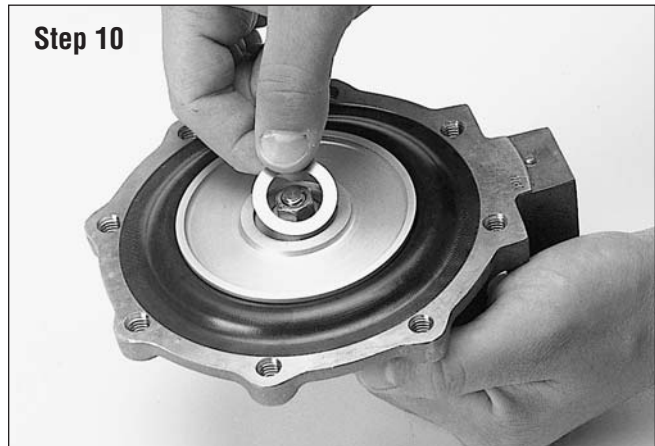

Figure 32 - Place one Spring Washer on the Diaphragm assembly.

11. Place Spring Case on Pilot Body with vent connection in any desired position. It is recommended that the vent connection be face down when the pilot is mounted on the regulator so that condensation will drain away instead of accumulating and possibly freezing (refer to Figure 33).



Figure 33 - Placing Spring Housing onto Pilot Body.

12. Install Spring Case Cap Screws - Use cap screws supplied and tighten in a criss / cross pattern to 5 ft-lbs torque.
13. Install appropriate Main Spring into Spring Case (refer to Figure 34 & Table 5).

Table 5

Color	Spring Range
White	5 inches W.C. - 15 inches W.C.
Brown	5 inches W.C. - 40 inches W.C.
Yellow	1 - 3 psig
Orange	2 - 5 psig
Gray	4 - 8 psig

MAINTENANCE (cont'd)

Pilot Assembly (cont'd)

Series 20L - Aluminum & Bronze Constructions

Step 13



Figure 34 - Installing the Spring into the Spring Case.

14. Place a small amount of petroleum grease such as Lubriplate No. 1051 on the remaining Spring Washer. This will help to hold it in a centered position on top of the main spring. Place the Spring Washer on top of the main spring. The washer prevents the Main Spring from "binding" when the Set Point Spring Adjuster is rotated (refer to Figure 35).

Step 14

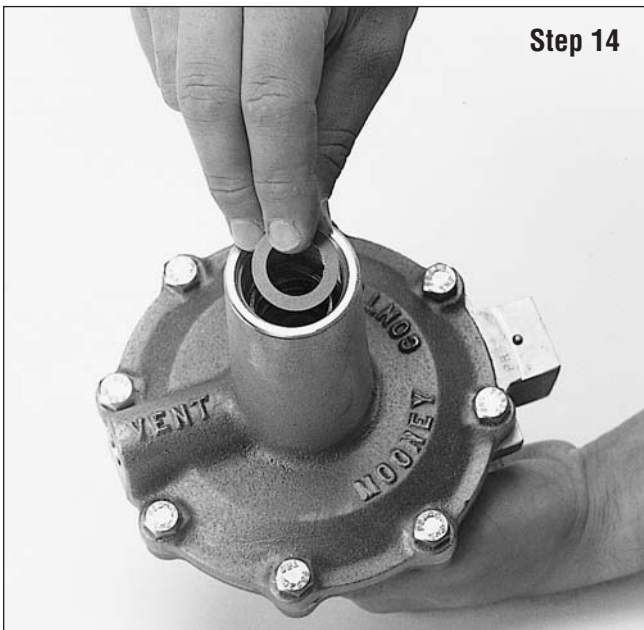

Figure 35 - Place a washer on top of the Main Spring.

15. Install Set Point Spring Adjuster and screw it into the Spring Housing at least 3/4" (refer to Figure 36).

Step 15



Figure 36 - Screw the Set Point Spring Adjuster 3/4" into the Spring Housing.

16. Place lubricated O-Ring on the spring housing Cover and screw into place (refer to Figure 37).

Step 16



Figure 37 - Screw the Cover with O-Ring into place.

NOTE: Overtightening an O-Ring Joint will not improve the seal. Screw in until metal parts make contact and snug slightly.

17. The Series 20L Pilot assembly is now complete.

GALVANIC CORROSION

All Series 20 Pilots

Refer to the chart below to determine the possibility of corrosion between dissimilar metals when installing a Body Insert (cartridge) made of a different material than the Pilot Body.

Table 6

Body Insert (Cartridge) Material	Pilot Body Material		
	Brass or Bronze (Series 20, 20H, 20L-B)	Stainless Steel (Series 20S, 20S, 20HS)	Aluminum (Series 20L-A)
Brass	A	A, D	C
Stainless Steel	B	A	B
Aluminum	A, D	A, D	A

KEY

- A: Corrosion of body material is not increased.
- B: Corrosion of body material is marginally increased.
- C: Corrosion of body material is greatly increased.
- D: Corrosion of Body Insert (cartridge) is increased.

SERIES 20L SECTIONAL VIEW

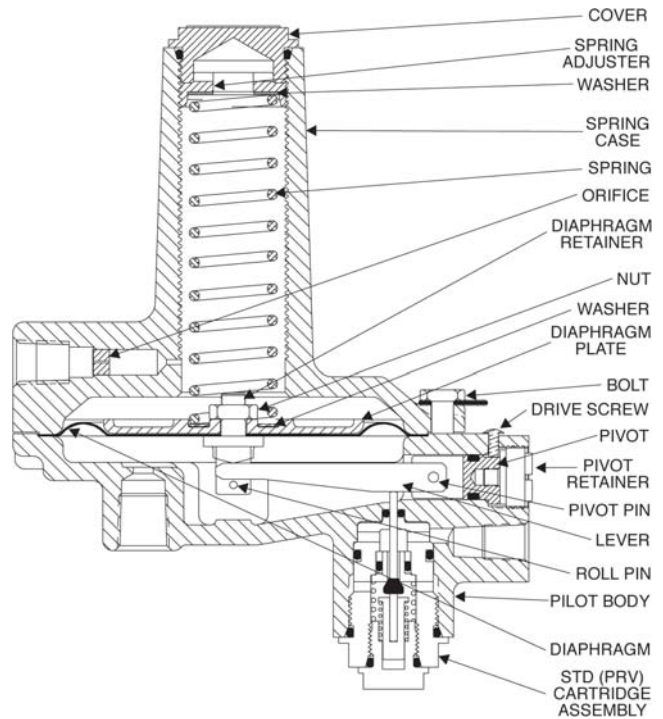

WARRANTY

LIMITED WARRANTY: Seller warrants title and that the goods manufactured by the Seller will be free from defects in materials and workmanship under normal use and service until the expiration of the earlier of twelve (12) months from the date of initial operation or eighteen (18) months from the date of shipment by Seller. Resale goods shall carry only the warranty extended by the original manufacturer to the original purchaser. If, within thirty (30) days after Buyer's discovery of any warranty defects, Buyer notifies Seller in writing, Seller shall, at its option, promptly repair or replace F.O.B. point of manufacture, that portion of the

goods found by Seller to be defective. Goods repaired and parts replaced during the warranty period shall be in warranty for the remainder of the original warranty period. This warranty is the only warranty made by Seller and can only be amended by a written instrument signed by an officer of Seller. Subject to this warranty and except as expressly provided **IN SALES LITERATURE, GE, INC. MAKES NO REPRESENTATION OR WARRANTY OF ANY KIND, EXPRESS OR IMPLIED, AS TO MERCHANTABILITY, FITNESS FOR PARTICULAR PURPOSE, OR ANY OTHER MATTER WITH RESPECT TO ANY OF THE PRODUCTS.**

While the information in this manual is presented in good faith and believed to be accurate, Mooney Controls, Inc. does not guarantee satisfactory results from reliance on such information. GE, Inc. reserves the right, without notice, to alter or improve the designs or specifications of the products described herein.